



PermaNET SU

Correlating Telemetry Noise Logger

PermaNET SU is the innovative new correlating noise logger from FCS.

Retaining the industry leading features of the PermaNET+ system, PermaNET SU combines a leak noise sensor and 4G LTE cellular communications technology into a compact single unit.

Designed specifically for smaller and more challenging installation environments, PermaNET SU is robust and durable.

PermaNET SU is fully compatible with PermaNET Web, the online data viewing and analysis platform, combining to provide GIS map-based display and full remote audio and autocorrelation functionality.



Key Features and Benefits

- **Single compact unit:** combines leak noise sensor and 4G LTE cellular communications into a single compact unit
- **Robust and durable:** designed specifically for smaller and more challenging installation environments
- **Quick response:** enables leakage teams to respond quickly to specific locations when a leak is detected
- **Installation confirmation:** daily check to confirm logger orientation; will alarm if a problem is detected
- **Secondary validation:**
 - Aqualog - detailed noise histogram to reduce 'false positives'
 - Remote leak audio file recordings
 - Remote correlation to localize leak position
- **Fully waterproof:** the IP68 rating has been tested at 10m depth over a 24 hour period
- **Easy to use:** compatible with the Deployment app and can also be programmed through PermaNET Web
- **PermaNET Web:** software supports
 - Correlation
 - GIS Interface
 - Map view
 - Remote reconfiguration
 - Aqualog
 - Filtering
- **External antennas:** for improved signal strength (contact FCS for more information)

Applications

Once installed, leak data is calculated using the proven PermaNET algorithm, and data is transmitted via low cost 4G LTE cellular connectivity. This removes the requirement for expensive site visits and "drive by" data retrieval.

PermaNET SU allows leakage teams to monitor the status of each logger deployed from a map based web dashboard using any internet enabled device.

Leaks are identified immediately. Once the presence of a leak has been identified, secondary measures can be used to check and remove 'false positives' and correlate the position of the leak.

MONITORING ASSETS, DELIVERING DATA, BRINGING CONTROL

www.fluidconservation.com

PermaNET SU

Correlating Telemetry Noise Logger

Operating Temperature	-20 to 60°C (-5 to 140°F)
Memory	Primary recording: 1 million readings
Dimensions	Height = 120mm, Diameter = 60mm
Weight	700g (1lb. 8.7oz)
Ingress Protection	IP68 submersible
Antenna	Multiple external options - contact FCS for more information
Expected Battery Life	5 years (depending on settings and signal condition)
Internal Cellular Modem	4G LTE Cat M1
Warranty	3-year limited warranty

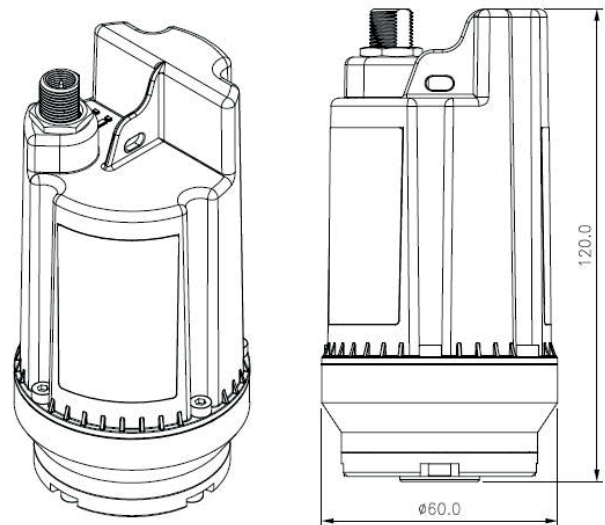

PermaNET Web

Online Data Portal

PermaNET Web is a secure, web-based portal designed to support the PermaNET product range in the remote identification of network leakage.

Supporting acoustic correlation, leak detection and logger programming, PermaNET Web delivers connectivity with multiple loggers and provides the user with numerous ways to view and analyze collected data.



All images, text and designs are protected by international and UK copyright law and remain the property of HWM. It is against the law to copy or use and of the content from HWM website or literature without the written consent of HWM. HWM Ltd. reserve the right to vary the specification.



Fluid Conservation Systems

502 TechneCenter Drive Suite B,
Milford, OH 45150
United States

Tel: +1 513 831 9335
Fax: +1 513 831 9336
Email: sales@fluidconservation.com
Web: www.fluidconservation.com

MONITORING ASSETS, DELIVERING DATA, BRINGING CONTROL